

Ferrolli

RVL

AIR-WATER CHILLERS AND HEAT PUMPS
WITH AXIAL FANS



TECHNICAL MANUAL

TABLE OF CONTENTS

GENERAL FEATURES	5
UNIT DESCRIPTION	5
UNIT IDENTIFICATION CODE	5
DESCRIPTION OF PARTS	6
VERSIONS	7
ACCESSORIES	8
TECHNICAL DATA AND PERFORMANCE	9
TECHNICAL DATA	9
NOMINAL PERFORMANCE IR	10
NOMINAL PERFORMANCE IP	10
PERFORMANCE IN COOLING (IR AND IP)	11
PERFORMANCE IN HEATING (IP)	12
WEIGHTS OF UNITS	13
ELECTRICAL DATA	13
NOISE LEVELS	13
PRESSURE LOSSES (VERSION VB)	14
USEFUL HEAD (VERSION VP AND VA)	14
OPERATION LIMITS	15
DIMENSIONS	16
CONNECTIONS	17
PLUMBING CONNECTIONS	17
EXPANSION TANK SETTING	18
ELECTRICAL CONNECTIONS	19

GENERAL FEATURES

Unit description

This series of air-water chillers and heat pumps has been designed to satisfy the air conditioning requirements of residential and commercial plants of small and medium size and can be applied both to fan coil plants and to radiant floor plants.

All the units are suitable for outdoor installation. The bearing structure and the panels are realized with galvanized and coated metal sheets to ensure a good protection against adverse weather conditions.

All the units are equipped with a compressor (**rotary or scroll** depending on the model), axial fans with safety protection grilles, finned coil realized with copper tubes and aluminium louvered fins, brazed plate heat exchanger thermally insulated to reduce heat dispersions and to avoid condensate generation and protected by means of a water differential pressure switch and of an antifreeze electrical heater.

As part of the standard outfit the units are equipped with variable speed control of the fans in order to allow the units to operate both with low outdoor temperature in cooling mode and with high outdoor temperature in heating mode as well as to reduce noise emissions in such operating conditions. All three-phase power supply units are provided with a phase presence and sequence monitoring device as part of the standard outfit.

Each model is available in 3 versions in order to match the different installation requirements :

- base version
- pump version
- pump and storage tank version.

The units operate with **R410A** refrigerant gas.

All the units are accurately built and individually tested in the factory. Only electric and hydraulic connections are required for installation.

Unit identification code

The codes that identify the units and the meaning of the letters used are described below.

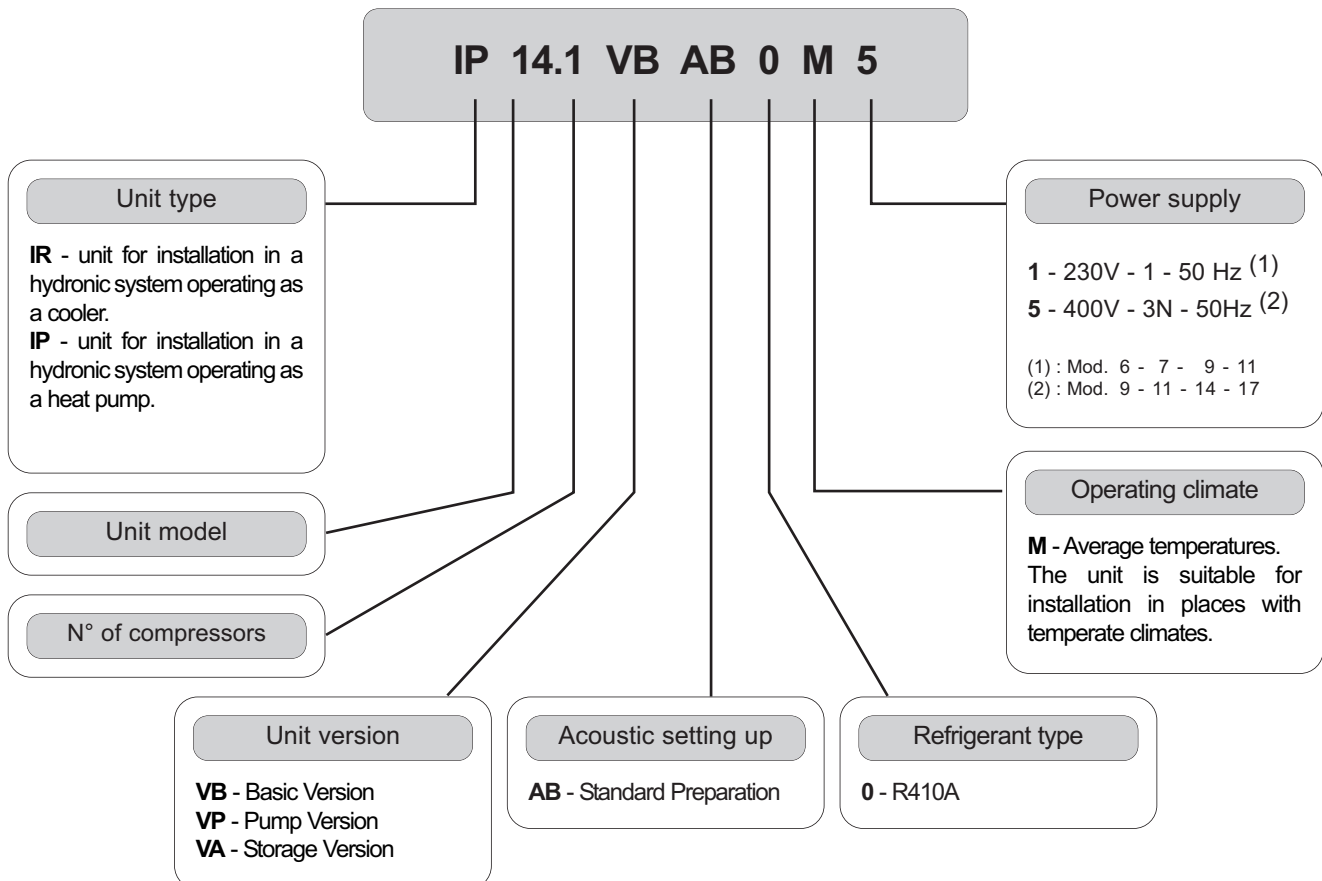

GENERAL FEATURES

Description of parts

The **supporting structure (1)**, base and external panelling are made from hot galvanised steel sheet, painted with epoxy powders (colour RAL 7035) to ensure good resistance to atmospheric agents.

The axial-type fans with curved profile blades **(2)** are housed in a sheet casing and are complete with safety grille. Fan speed is controlled in a continuous way by a phase cut device that allows the condensing pressure (in cooling) and evaporation pressure (in heating) to be controlled according to the value read by the temperature probe on the liquid line.

The rotary type hermetic **compressor (3)** (models 6 or 7) or scroll (models 9, 11, 14 and 17) is complete with overtemperature and overcurrent protection. It is fixed to the base by means of rubber vibration dampers and placed in a compartment separate from the air flow to facilitate maintenance and control operations. To prevent reverse compressor rotation on all the units with three-phase power supply, a device that controls the presence and correct sequence of the power phases is fitted. Units in heat pump version have a heating element that is activated when the compressor switches off, to keep the compressor crankcase oil temperature high enough to prevent migration of the refrigerant during winter stops and to evaporate any liquid present in the crankcase, in order to prevent possible liquid rushes on starting.

The braze-welded stainless steel plate-type exchanger **on the user side (4)** is adequately insulated to prevent the formation of condensate and to limit heat loss to the outside. It is protected against the risk of ice forming by an antifreeze heating element activated according to the water temperature and by a differential pressure switch that detects a possible lack of water flow.

The **external side exchanger (5)** comprises a finned coil with grooved copper pipes arranged in an equilateral shape and aluminium fins with notched profile to increase the heat exchange coefficient. A tray is obtained in the base for collecting the condensate produced during heating operation.

The lamination part comprises a thermostatic valve **(6)** with external equaliser that allows the unit to adjust to the various operation conditions, keeping the set level of overheating constant.

The refrigerant circuit of each unit is also complete with :

- **hermetic dehydrator filter** with solid cartridge **(7)** : it catches residuals of impurities and any traces of moisture in the circuit;
- **high pressure switch (8)** : with fixed setting and manual reset;
- **low pressure switch (9)** : with fixed setting and automatic reset (it becomes manual only in case of frequent activations);
- **4-way reverse cycle valve (10)** : it allows the switching of operation mode, reversing the refrigerant flow (for units in heat pump version only);
- **liquid receiver (11)**: it compensates the variation in refrigerant charge required with the change of operation mode (for units in heat pump version only);
- **pressure test points (12)** SAE 5/16" (UNF 1/2" - 20) complete with pin, seal and blind union, as required for the use of refrigerant R410A. They enable a complete check of the refrigerant circuit : compressor inlet pressure, compressor delivery pressure, pressure upstream of the thermostatic valve and pressure losses on the dehydrator filter.

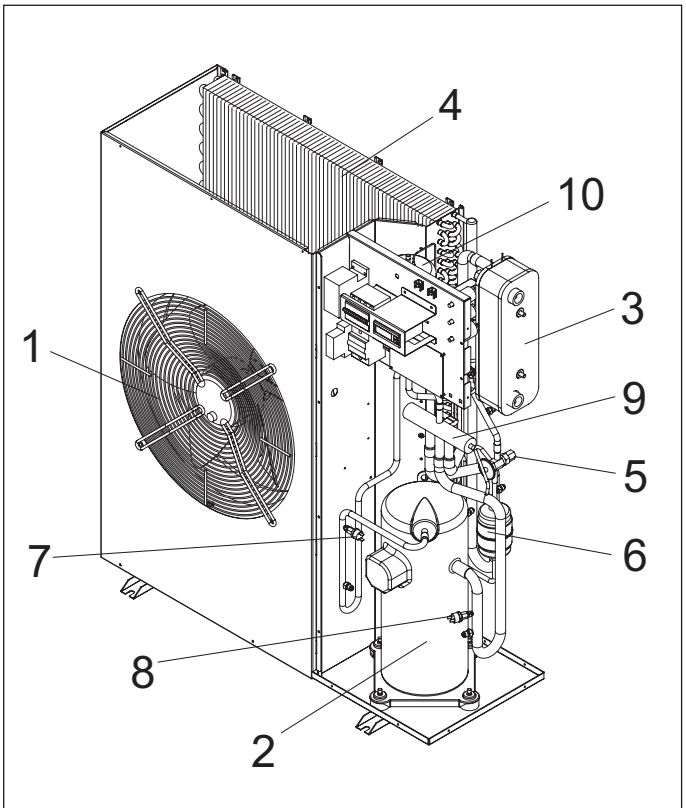

GENERAL FEATURES

The command and control **electrical panel** incorporated in the unit contains all the power, adjustment and safety components necessary to guarantee correct operation. The main switch and user interface are accessible from the outside by opening a hermetic door.

The main components are :

- main switch (thermal magnetic)
- microprocessor controller with user interface and incorporated phase cut card
- compressor contactor
- wiring board with transformer, protection fuses and user terminal block
- mesh filter
- compressor start condenser (units with single-phase power supply only)
- start condenser for fans

- device for control of presence and correct power supply phase sequence (units with three-phase power supply only)

The unit is managed by a **microprocessor controller** to which all the loads and control devices are connected by means of a wiring board. The user interface comprises a

display and 4 buttons for displaying and possibly modifying all the unit's operation parameters. A remote keyboard with all the functions of the interface fitted on the machine is available as an accessory.

The main functions available are :

- adjustment of treated water temperature (by setting the setpoint)
- climate control in heating (modification of setpoint according to the outside air temperature)
- dynamic defrost according to outside air temperature
- display of active alarms and alarms history
- continuous fan speed control
- pump management
- recording of compressor and pump operation hours
- serial communication by Modbus protocol
- remote standby
- remote cooling-heating
- digital output for general alarm

Versions

Each model can be supplied in three different versions to meet the application needs of the systems. The unit always comes assembled, wired and factory-tested.

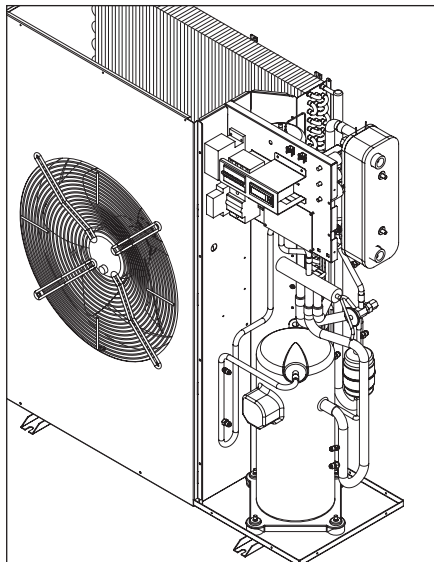

Basic Version - VB

The unit does not contain a circulating pump or storage tank. Therefore an adequate flow of water through the plate-type exchanger must be guaranteed to prevent activation of the internal safety devices. If adequately sized, the pump can in any case be connected to the unit's electrical panel and managed by the controller.

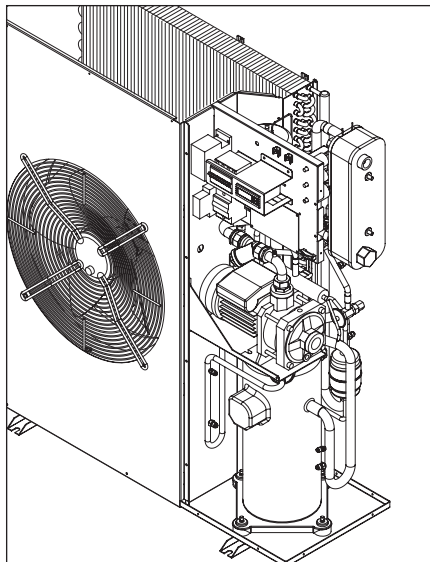

Pump Version - VP

The unit contains a circulating pump, metal cartridge filter (to protect the plate-type exchanger), air vents and drain cock.

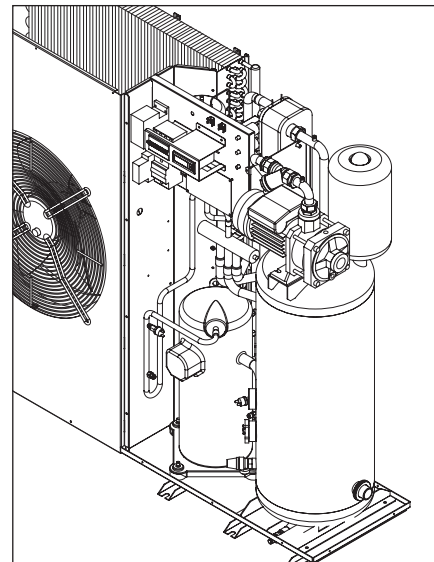

Storage Version - VA

The unit contains a storage tank (configured as storage on the delivery to the system), circulating pump, metal cartridge filter (to protect the plate-type exchanger), air vents, safety valve, expansion tank and drain cock. The tank is also arranged for fitting antifreeze or supplementary heating elements.

GENERAL FEATURES

Accessories

Coil protection grilles - GP

It comprises a painted electrowelded grille that protects the finned coil.

Rubber vibration dampers - AVG

These reduce the transmission to the machine support surface of mechanical vibrations generated by the compressor and fans during their normal operation. The number of vibration dampers depends on the version. To ensure the efficiency of this accessory it is advisable to use vibration-damping joints on the plumbing connections.

Tank antifreeze heating element - RAG

Activated together with the plate-type exchanger antifreeze heating element, its purpose is to keep the water in the storage tank at a suitable temperature to prevent ice forming during winter idle periods.

Supplementary heating elements - REL

They supplement or substitute the heating power supplied by the heat pump and are managed by the unit's controller with two-step logic. They also substitute the tank antifreeze heating element accessory (RAG).

Remote control - CR

The remote control is suitable for wall mounting and has all the control and display functions available on the unit's interface. It therefore enables complete remote control of the unit.

Serial interface - KMB

It enables communication with the unit's controller and monitoring the operating conditions by means of Modbus communication protocol. Use of the RS485 serial line ensures the quality of the signal up to distances of approx. 1200 metres (extendable by means of special repeaters).

Programmer clock - OP

It allows the unit to be turned on and off according to a preset programme by operating on the digital input available on the unit's control card (remote on-off).

MODEL ABBREV. ACCESSORY		Version		
		VB	VP	VA
GP	Coil protection grilles	F	F	F
AVG	Rubber vibration dampers	F	F	F
RAG	Tank antifreeze heating element	-	-	F
REL	Supplementary heating elements	-	-	M
CR	Remote control	F	F	F
KMB	Serial interface	F	F	F
OP	Programmer clock	F	F	F

M : accessory factory-installed

F : accessory supplied (installation to be carried out by the customer)

TECHNICAL DATA AND PERFORMANCE

Technical data

Frame	1		2				3		U.M.
Model	6.1	7.1	9.1		11.1		14.1	17.1	U.M.
Electrical power supply	230-1-50	230-1-50	230-1-50	400-3N-50	230-1-50	400-3N-50	400-3N-50	400-3N-50	V-ph-Hz
Compressor									
Type	rotativo		scroll						-
Quantity	1								n°
Capacity steps	0 - 100								%
Oil charge	1,13	1,13	1,20	1,20	1,80	1,80	1,80	1,80	kg
Refrigerant									
Type	R410A								-
Refrigerant									
Type	axial								-
Quantity	1				2				n°
Diameter	450		500						mm
Max. rotation speed	900								rpm
Total installed power	0,15		0,21				0,42		kW
Plate-type heat exchanger									
Type	braze-welded plates								-
Quantity	1								n°
Water content	0,29	0,29	0,46	0,46	0,46	0,46	0,53	0,72	l
Finned coil									
Type	copper pipes - aluminium fins								-
Quantity	1								n°
Front surface	0,60		0,77				0,98		m ²
Pump (versions VP and VA)									
Type	circulating pump		multistage centrifugal pump						-
Quantity	1								n°
Installed power	0,20		0,75						kW
Storage tank (version VA)									
Storage volume	33		50				71		l
Safety valve setting	6								bar
Expansion tank volume	5								l
Tank antifreeze heating element - RAG									
Power	0,25								kW
Supplementary heating elements - REL									
Power	3,3		3,3 / 6,6				6,6		kW
Capacity steps	2								n°

TECHNICAL DATA AND PERFORMANCE

Nominal performance IR

Frame	1		2				3		U.M.
	6.1	7.1	9.1		11.1		14.1	17.1	
Electrical power supply	230-1-50		230-1-50	400-3N-50	230-1-50	400-3N-50	400-3N-50		V-ph-Hz
Cooling (air 35 °C bs / water 12 - 7 °C)									
Refrigerating capacity ^(E)	6,20	7,40	9,40	9,40	10,8	10,8	13,8	17,3	kW
Total input ^{(VB)(E)}	2,15	2,85	3,70	3,70	4,15	4,15	5,15	6,65	kW
total EER ^{(VB)(E)}	2,88	2,60	2,54	2,54	2,60	2,60	2,68	2,60	-
Water delivery	1066	1273	1617	1617	1858	1858	2374	2976	l/h
Pressure losses ^{(VB)(E)}	28	38	26	26	33	33	40	35	kPa
Useful head ^(VP-VA)	73	58	170	170	152	152	122	96	kPa
Cooling (air 35 °C bs / water 23 - 18 °C)									
Refrigerating capacity	7,40	8,90	11,3	11,3	13,0	13,0	16,6	20,8	kW
Total input ^(VB)	2,20	2,90	3,80	3,80	4,25	4,25	5,30	6,85	kW
Total EER ^(VB)	3,36	3,07	2,97	2,97	3,06	3,06	3,13	3,04	-
Water delivery	1273	1531	1944	1944	2236	2236	2855	3578	l/h
Pressure losses ^{(VB)(E)}	38	53	36	36	46	46	56	49	kPa
Useful head ^(VP-VA)	58	37	146	146	122	122	82	49	kPa
ESEER^{(VB)(E)}	3,26	2,94	2,88	2,88	2,94	2,94	3,04	2,94	-

Nominal performance IP

Frame	1		2				3		U.M.
	6.1	7.1	9.1		11.1		14.1	17.1	
Electrical power supply	230-1-50	230-1-50	230-1-50	400-3N-50	230-1-50	400-3N-50	400-3N-50	400-3N-50	V-ph-Hz
Cooling (air 35 °C bs / water 12 - 7 °C)									
Refrigerating capacity ^(E)	6,00	7,10	9,20	9,20	10,6	10,6	13,6	17,1	kW
Total input ^{(VB)(E)}	2,15	2,85	3,70	3,70	4,15	4,15	5,15	6,65	kW
Total EER ^{(VB)(E)}	2,79	2,49	2,49	2,49	2,55	2,55	2,64	2,57	-
Water delivery	1032	1221	1582	1582	1823	1823	2339	2941	l/h
Pressure losses ^{(VB)(E)}	26	35	25	25	32	32	39	34	kPa
Useful head ^(VP-VA)	75	62	173	173	155	155	124	99	kPa
Cooling (air 35 °C bs / water 23 - 18 °C)									
Refrigerating capacity	7,20	8,50	11,0	11,0	12,8	12,8	16,3	20,5	kW
Total input ^(VB)	2,20	2,90	3,80	3,80	4,25	4,25	5,30	6,85	kW
Total EER ^(VB)	3,27	2,93	2,89	2,89	3,01	3,01	3,08	2,99	-
Water delivery	1238	1462	1892	1892	2202	2202	2804	3526	l/h
Pressure losses ^{(VB)(E)}	36	49	34	34	45	45	54	48	kPa
Useful head ^(VP-VA)	60	43	150	150	125	125	86	53	kPa
ESEER^{(VB)(E)}	3,16	2,82	2,82	2,82	2,89	2,89	2,99	2,91	-
Heating (air 7 °C bs - 6 °C bu / water 40 - 45 °C)									
Heat output ^(E)	7,00	8,20	10,4	10,4	11,5	11,5	15,3	18,6	kW
Total input ^{(VB)(E)}	2,25	2,75	3,65	3,65	4,05	4,05	4,95	6,40	kW
Total COP ^{(VB)(E)}	3,11	2,98	2,85	2,85	2,84	2,84	3,09	2,91	-
Water delivery	1204	1410	1789	1789	1978	1978	2632	3199	l/h
Pressure losses ^{(VB)(E)}	34	46	31	31	37	37	48	40	kPa
Useful head ^(VP-VA)	63	47	157	157	143	143	101	79	kPa
Heating (air 7 °C bs - 6 °C bu / water 30 - 35 °C)									
Heat output	7,20	8,40	10,6	10,6	11,7	11,7	15,6	19,0	kW
Total input ^(VB)	1,90	2,35	3,05	3,05	3,40	3,40	4,15	5,40	kW
Total COP ^(VB)	3,79	3,57	3,48	3,48	3,44	3,44	3,76	3,52	-
Water delivery	1238	1445	1823	1823	2012	2012	2683	3268	l/h
Pressure losses ^{(VB)(E)}	36	48	32	32	38	38	50	42	kPa
Useful head ^(VP-VA)	60	44	155	155	140	140	97	74	kPa

(VB) : only for base version **VB**
(VP-VA) : only for pump version **VP** and tank version **VA**
(E) : data declared according to **EUROVENT** certification programme

TECHNICAL DATA AND PERFORMANCE

Performance in cooling (IR and IP)

Refrigerating capacity

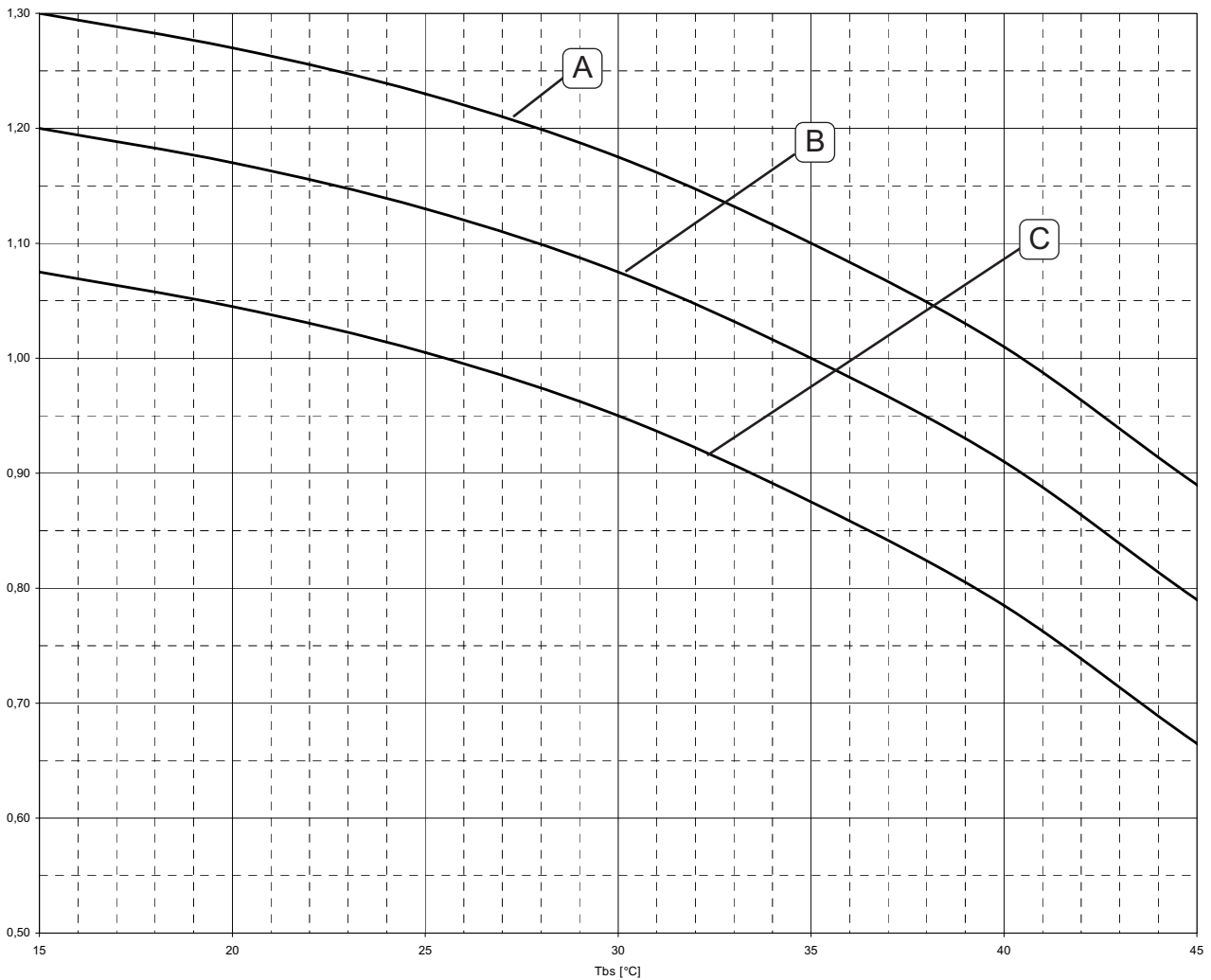

Power input

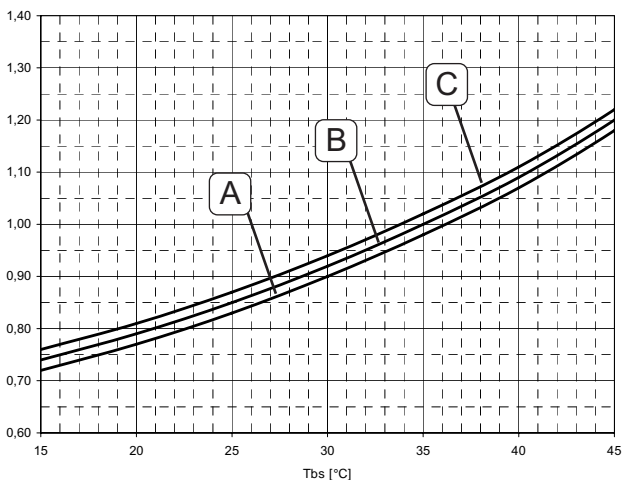

EER

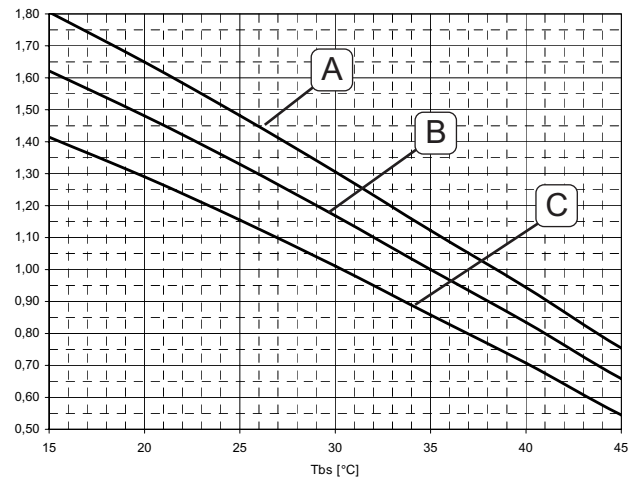

Temperature of water produced:

A = 10°C

B = 7°C

C = 4°C

The graphs provided above can be used to obtain the correction coefficients to be applied to the nominal performance values (air 35°C bs / air 12-7°C) for obtaining the real performance values in the chosen operating conditions.

TECHNICAL DATA AND PERFORMANCE

Performance in heating (IP)

Heat output

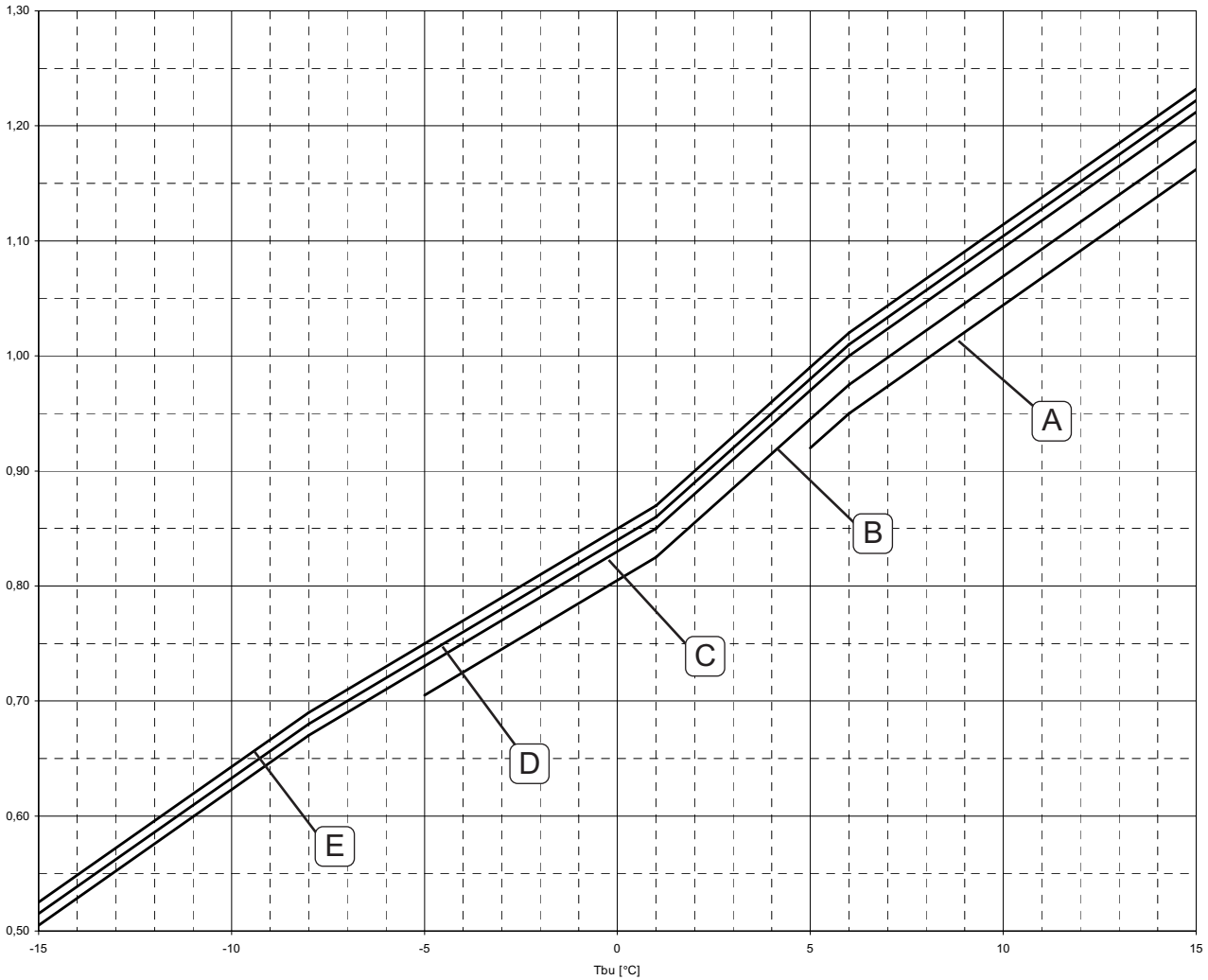

Power input

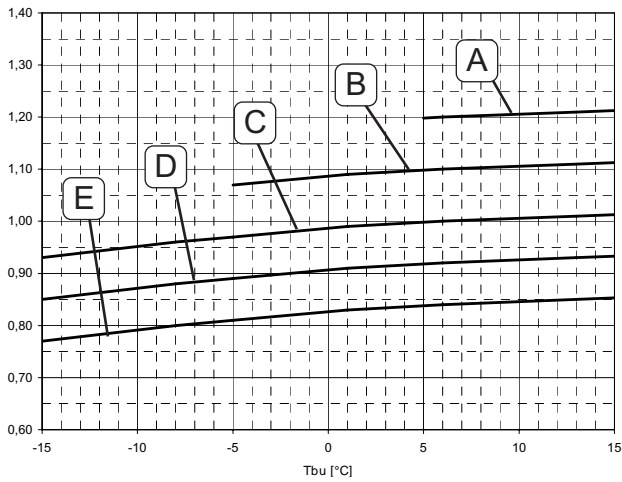

COP

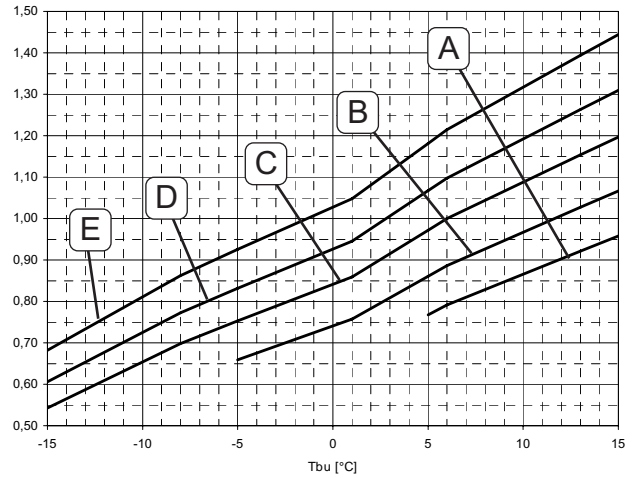

Temperature of water produced:

- A = 55°C
- B = 50°C
- C = 45°C
- D = 40°C
- E = 35°C

The graphs given above can be used to obtain the correction coefficients to be applied to the nominal performance values (air 7°C bs - 6°C bu / water 40-45°C) for obtaining the real performance values in the chosen operating conditions.

TECHNICAL DATA AND PERFORMANCE

Weights of units

	Frame	Model	Weight of unit [kg]			Transport weight [kg]		
			VB	VP	VA	VB	VP	VA
IR	1	6.1	86.5	94.5	114.0	92.0	100.0	123.0
		7.1	92.5	100.5	120.0	98.0	106.0	129.0
	2	9.1	104.5	118.5	147.0	110.0	124.0	156.0
		11.1	122.5	136.5	165.0	128.0	142.0	174.0
	3	14.1	138.0	152.0	188.5	143.5	157.5	197.5
		17.1	147.0	161.0	197.5	152.5	166.5	206.5
IP	1	6.1	88.0	96.0	115.5	93.5	101.5	124.5
		7.1	94.5	102.5	122.0	100.0	108.0	131.0
	2	9.1	107.0	121.0	149.5	112.5	126.5	158.5
		11.1	125.0	139.0	167.5	130.5	144.5	176.5
	3	14.1	140.5	154.5	191.0	146.0	160.0	200.0
		17.1	150.0	164.0	200.5	155.5	169.5	209.5

Electrical data

Frame Model	1		2		3			U.M.	
	6.1	7.1	9.1	11.1	14.1	17.1			
Power supply	230-1-50	230-1-50	230-1-50	400-3N-50	230-1-50	400-3N-50	400-3N-50	400-3N-50	V-ph-Hz
Version VB *									
F.L.A. - Total max. absorbed current	12.9	16.1	22.8	9.1	27.0	10.7	14.2	17.1	A
F.L.I. - Total max. power input	2.8	3.5	4.9	4.9	5.8	5.8	7.5	9.2	kW
M.I.C. - Total max. peak current	49.8	68.8	89.1	48.1	121.1	51.1	67.1	70.1	A
Version VP and VA *									
F.L.A. - Total max. absorbed current	14.1	17.3	26.7	13.0	30.9	14.6	18.1	21.0	A
F.L.I. - Total max. power input	3.1	3.8	5.8	5.8	6.7	6.7	8.4	10.1	kW
M.I.C. - Total max. peak current	49.8	68.8	89.1	48.1	121.1	51.1	67.1	70.1	A
Supplementary electrical heating elements : 3,3 kW									
F.L.A. - Total max. absorbed current	14,3	14,3	14,3	4,8	14,3	4,8	-	-	A
F.L.I. - Total max. power input	3,3	3,3	3,3	3,3	3,3	3,3	-	-	kW
Supplementary electrical heating elements : 6,6 kW									
F.L.A. - Total max. absorbed current	-	-	28,7	9,5	28,7	9,5	9,5	9,5	A
F.L.I. - Total max. power input	-	-	6,6	6,6	6,6	6,6	6,6	6,6	kW

* Possible accessories excluded.

Noise levels

Model	Sound power levels [dB] for octave bands [Hz]								Sound power level		Sound pressure level at 1 m
	63	125	250	500	1000	2000	4000	8000	[dB]	[dB(A)]	[dB(A)]
6.1	74.6	72.5	70.8	67.1	63.6	59.4	53.7	46.2	78	69	55
7.1	74.6	72.5	70.8	67.1	63.6	59.4	53.7	46.2	78	69	55
9.1	77.4	75.3	73.6	69.9	66.4	62.2	56.5	49.0	81	72	57
11.1	77.4	75.3	73.6	69.9	66.4	62.2	56.5	49.0	81	72	57
14.1	79.5	77.4	75.7	72.0	68.5	64.3	58.6	51.1	83	74	59
17.1	79.5	77.4	75.7	72.0	68.5	64.3	58.6	51.1	83	74	59

Reference conditions

Performance values for standard version (VB) operating in cooling mode in NOMINAL conditions.

Unit positioned in free field on a reflecting surface (directivity factor equal to 2).

The sound power level is measured according to Standard ISO 3744.

The sound pressure level is calculated according to ISO 3744 (Eurovent 8/1) and refers to a distance of 1 metre from the external surface of the unit.

TECHNICAL DATA AND PERFORMANCE

Pressure losses (version VB)

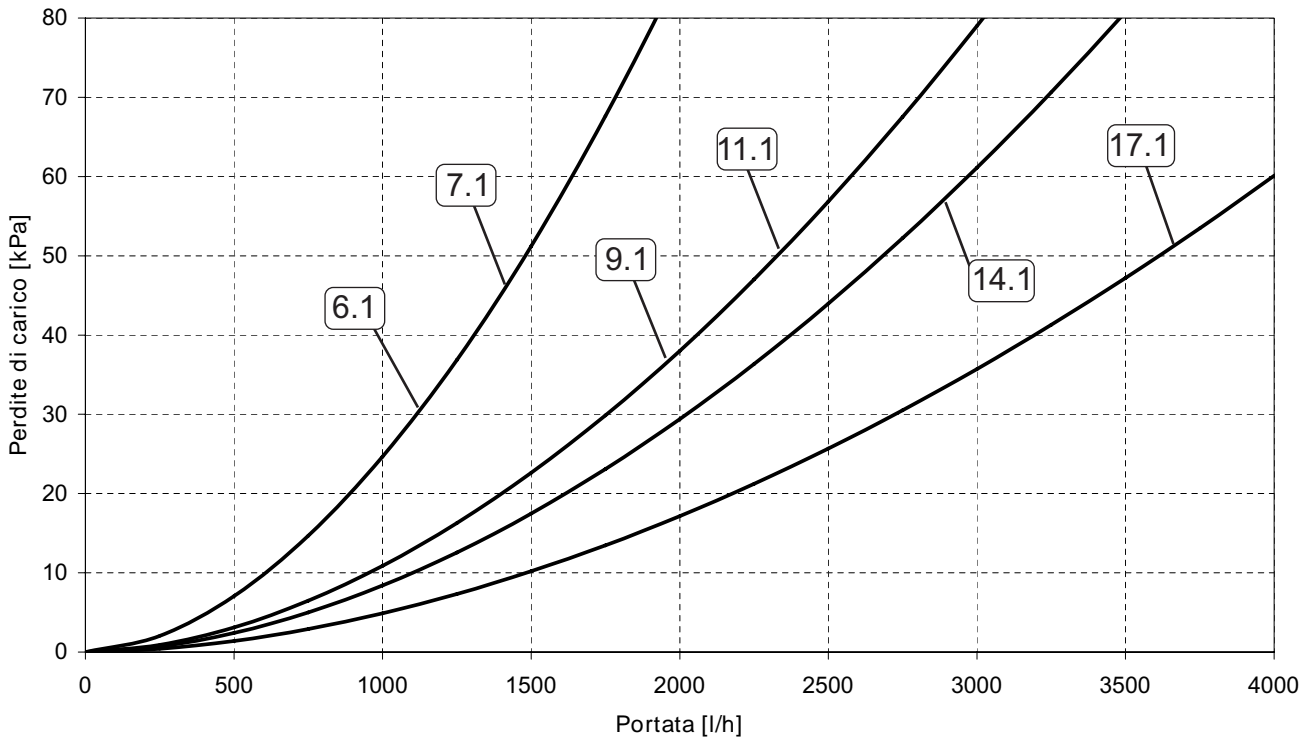

Useful head (version VP and VA)

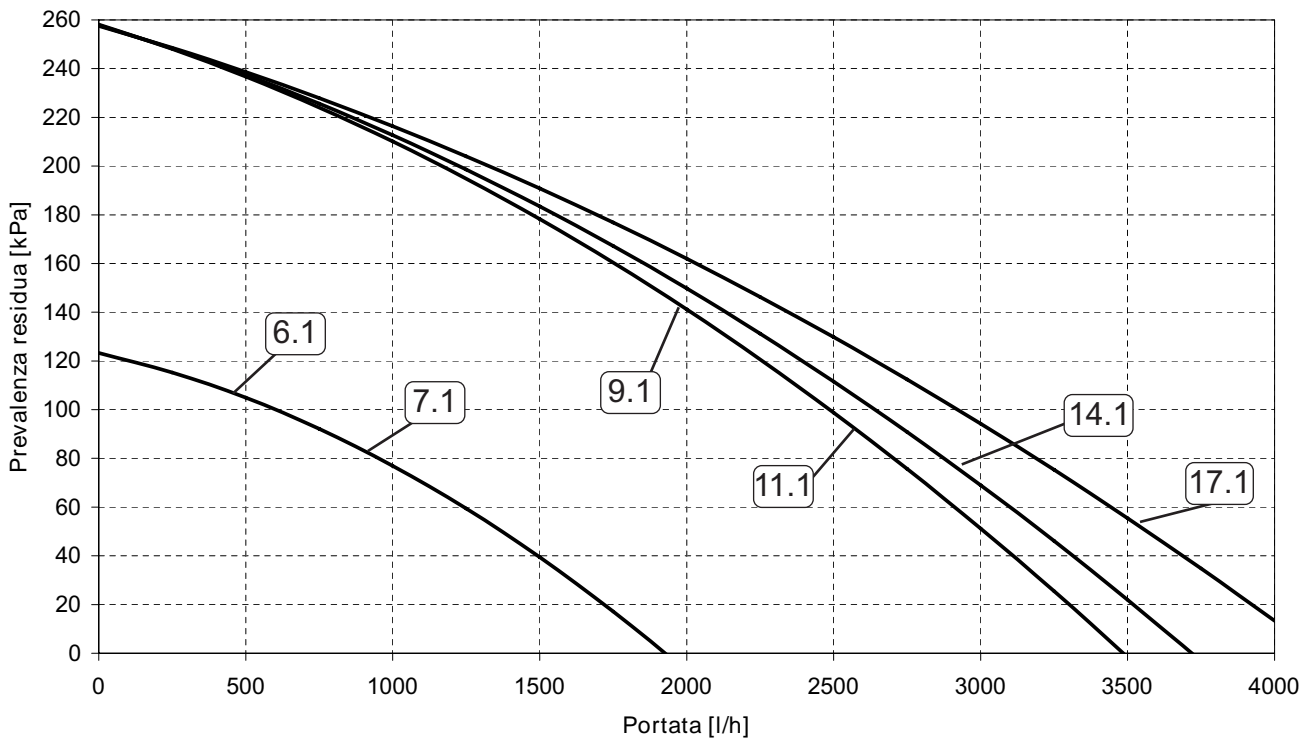

TECHNICAL DATA AND PERFORMANCE

Operation limits

The graphs provided below give the range within which correct operation of the unit is guaranteed. Use in different conditions from that indicated involves cancellation of the product warranty contract.

Thermal head of water treated by the unit		
Minimum	3	°C
Maximum	8	°C

IN COOLING

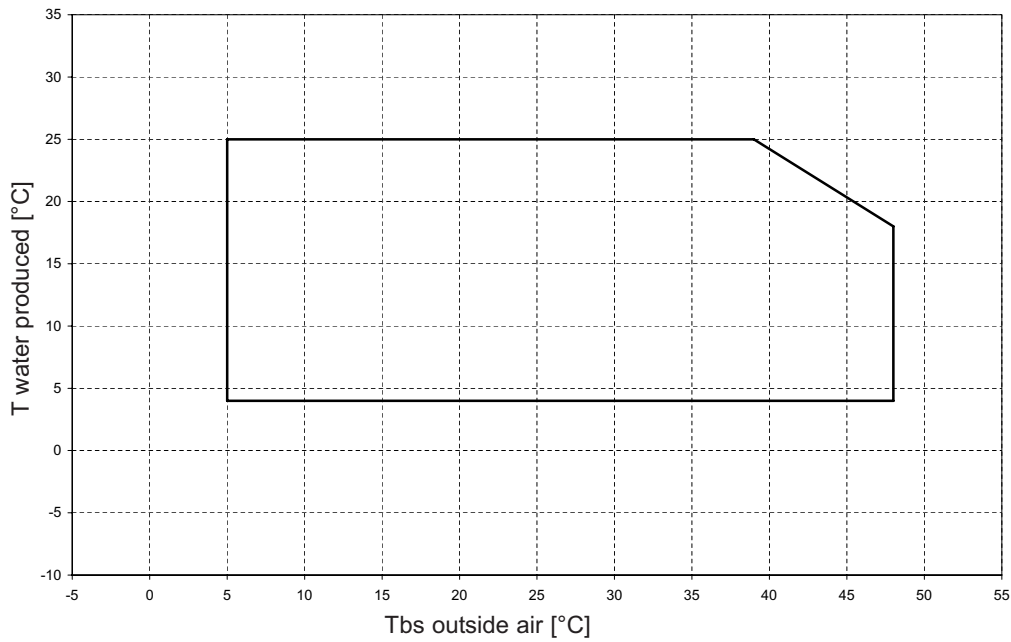

IN HEATING

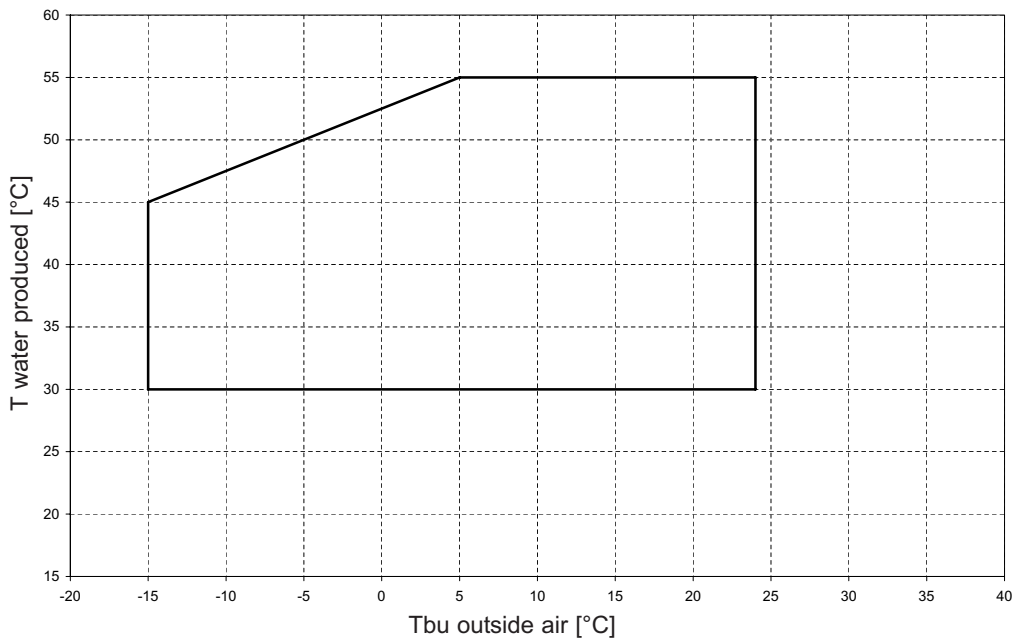

TECHNICAL DATA AND PERFORMANCE

Dimensions

Basic Version - VB

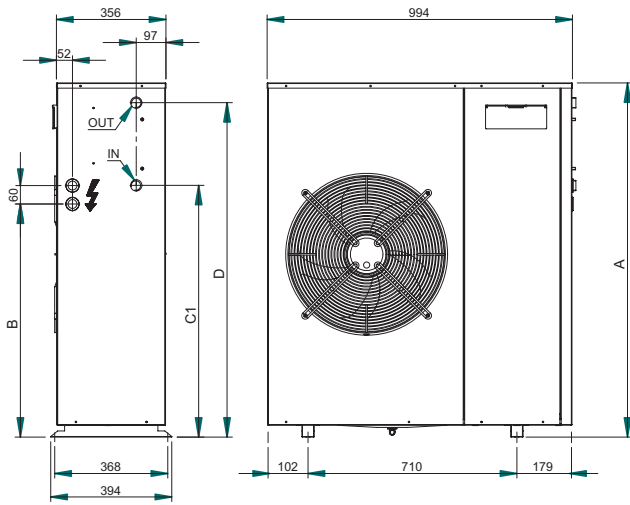

Pump Version - VP

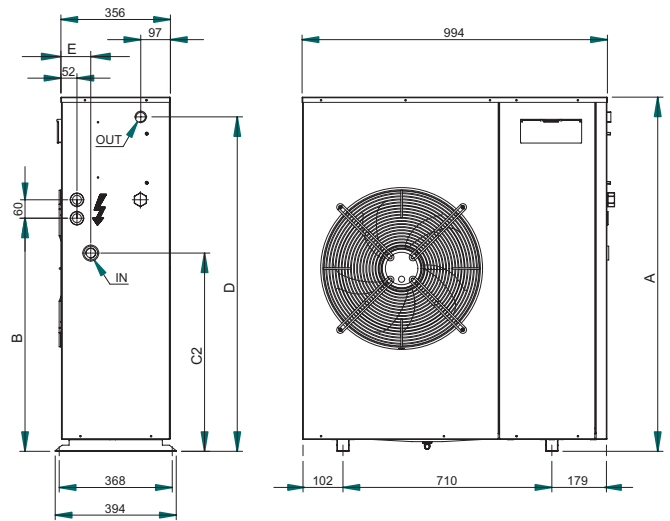

Storage Version - VA

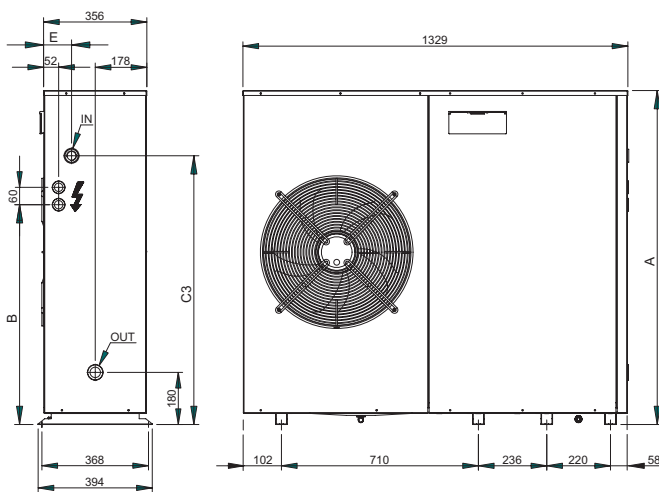

Minimum operating space

Respect the clearances around the unit indicated in the figure, to ensure adequate air circulation and to facilitate maintenance and control operations.

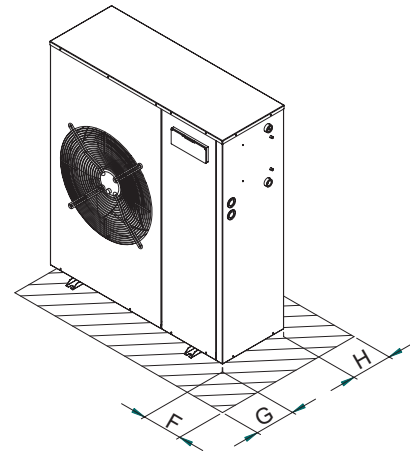

Frame	1			2			3			U.M.
Model	6.1 - 7.1			9.1 - 11.1			14.1 - 17.1			
Version	VB	VP	VA	VB	VP	VA	VB	VP	VA	
A		903			1153			1453		mm
B		509			759			1059		mm
C1		570			820			1120		mm
C2		545			646			946		mm
C3		799			928			1228		mm
D		839			1089			1389		mm
E		142			97			97		mm
F					400					mm
G					600					mm
H					200					mm
IN	1	1	1	1	1	1	1	1	1	inch
OUT	1	1	1	1	1	1	1	1	1	inch

CONNECTIONS

Plumbing connections

For correct design of the plumbing system comply with the current local safety regulations.

Always ensure an adequate flow of water through the unit's plate-type exchanger, even if a differential pressure switch (connected between the exchanger inlet and outlet) that stops the unit in case of insufficient water flows, thus preventing the risk of freezing, is fitted standard. For that purpose, an antifreeze heating element is also fitted on the plate-type exchanger of all the units.

To adjust the water flow through the exchanger it is advisable to install a cock at the outlet of the unit.

Basic version (VB) units must be fitted with a mesh filter (\varnothing holes $\geq 500 \mu\text{m}$) at the plate-type exchanger inlet to catch any foreign substances; the warranty is cancelled if this filter is not fitted.

The plumbing circuit must be kept under pressure using an expansion tank in combination with a safety valve (these parts are already present in the storage version - VA). A filling unit that automatically fills the system and maintains the required pressure can be used.

Precautions during the winter period

In case of a system stop during the winter period, the water could freeze and damage the unit's exchanger and other parts of the system. To prevent these problems, three solutions are possible:

1. Completely drain the system, paying attention to emptying the plate-type exchanger (open the air vents to facilitate the operation).
2. Use water with glycol remembering that, according to the quantity of glycols used, the unit's performance must be adjusted by means of correction factors for the refrigerating capacity, input, water delivery and pressure losses.
3. Keep the unit electrically connected throughout the winter. The plate-type exchanger is protected by the antifreeze heating element fitted standard. The circulating pump is activated by the unit's controller according to the outside air temperature, to protect the pipes. Units in storage version (VA) are supplied with an antifreeze heating element, as an accessory to prevent ice forming inside the tank, activated by the unit's controller together with the antifreeze heating element of the plate-type exchanger. The supplementary heating elements, if present, also carry out the antifreeze function.

Suggestions for the plumbing system

Prepare the pipes with the least possible number of bends to minimise pressure losses, and suitably support them to prevent excessive stresses at the unit's connections.

Install shut-off valves near the parts subject to maintenance, to allow their replacement without having to drain the system.

Provide for manual or automatic valves in the highest part of the circuit to vent the air.

Make sure there are no leaks before insulating the pipes and filling the system.

Insulate all the refrigerated water pipes to prevent the formation of condensate, using steam barrier type material (otherwise cover the insulation with appropriate protection). Also make sure the air vent valves are always accessible.

Arrange adequate connections for reading the pressure and temperature at the inlet and outlet of the unit, for possible control of correct system operation.

Coil condensate drain

The condensate produced by the coil during heating operation is collected in the tray obtained in the base of the unit and can be drained by connecting a tube to the union supplied standard on all units in heat pump version.

CONNECTIONS

Expansion tank setting

All the storage version units (VA) come complete with expansion tank and safety valve. The expansion tank prefilling pressure must be adequate for the total volume of the plumbing system to which the unit is connected.

The factory setting ($p_{VE} = 2 \text{ bar g}$) corresponds to the minimum value necessary for avoiding negative pressure zones inside the water circuit and the risk of pump cavitation, in the event no users are located above the level on which the unit is installed. In this case the prefilling pressure must be increased according to the level of the highest user according to the following relationship :

$$p_{VE} = 2 + \frac{H_{\max}}{9,81}$$

p_{VE} : expansion tank prefilling pressure [bar g]
 H_{\max} : height difference between the highest user and the unit installation level [m]

When the prefilling pressure increases the maximum volume of the system supported by the expansion tank supplied standard decreases. If the actual volume of the system is greater than that maximum value, an additional expansion tank of adequate capacity must be installed.

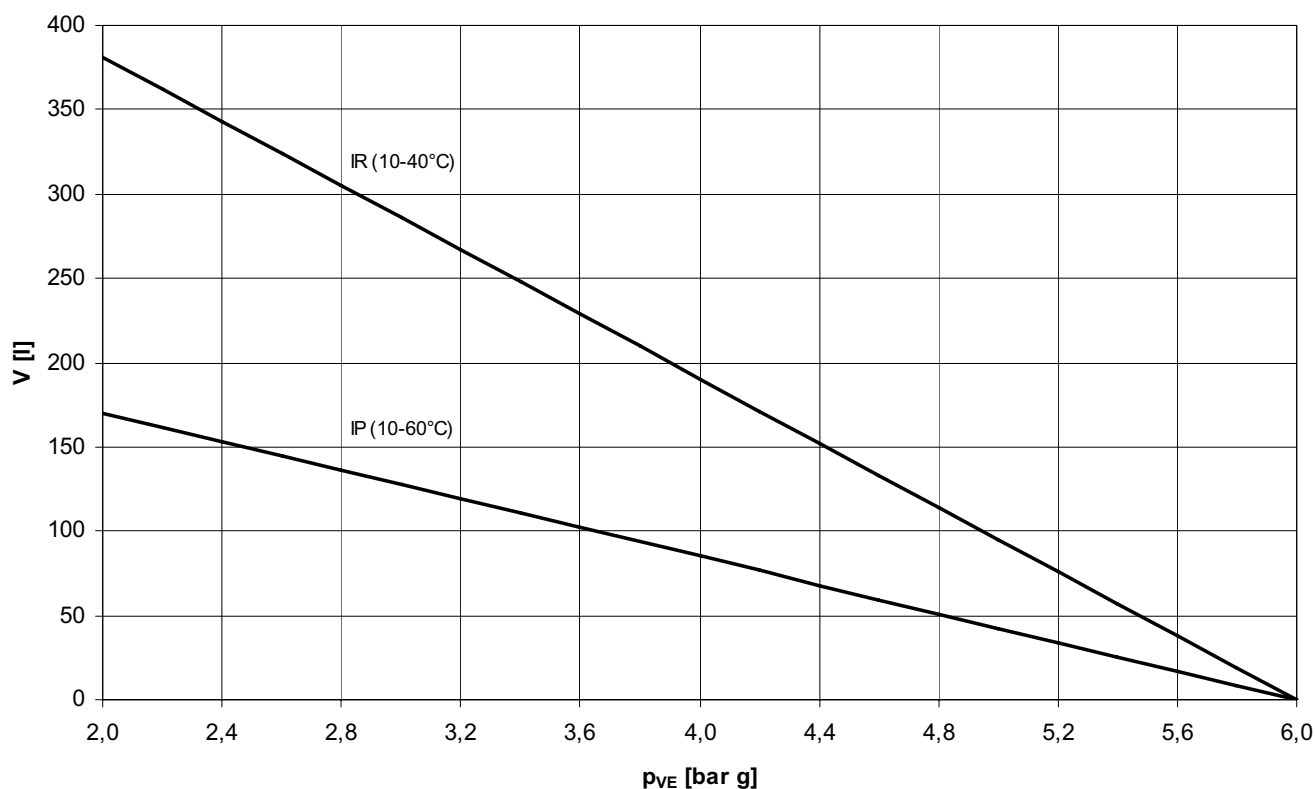

For units operating with water and glycols calculate the maximum value, applying the correction factors given in the following table to values obtained from the graph.

glycol %	Ethylene glycols				Propylene glycols			
	10%	20%	30%	40%	10%	20%	30%	40%
IR (10-40°C)	0.738	0.693	0.652	0.615	0.700	0.608	0.543	0.494
IP (10-60°C)	0.855	0.811	0.769	0.731	0.814	0.718	0.647	0.593

The maximum expansion tank prefilling pressure corresponds to the safety valve setting value (6 bar g). After the water circuit is filled, the pressure at the expansion tank must not be higher than the prefilling pressure. In case of users located at levels below that on which the unit is installed, make sure the user can take the maximum pressure generated.

CONNECTIONS

Electrical connections

The electrical wiring must be carried out by qualified personnel in conformity with the current regulations in the country of use at the time of installation. Before carrying out any work on the electrical system make sure the unit's power supply line is disconnected at the start.

N.B. Refer to the wiring diagram attached to the unit.

Connection to the power supply

The units come completely factory-wired and arranged for connection to the mains.

The power cables of the unit's supply line must be taken :

- for units with **single-phase** power supply : from a single-phase voltage system provided with neutral wire and separate earth wire;

$$V = 230 V \pm 10 \%$$

$$f = 50 \text{ Hz}$$

- for units with **three-phase** power supply : from a symmetrical three-phase voltage system provided with neutral wire and separate earth wire.

$$V = 400 V \pm 10 \%$$

$$f = 50 \text{ Hz}$$

The power cables must enter the unit through the holes provided in the side panel and be connected to the unit's main switch. The earth wire coming from the power supply line must be connected directly to the plate on the electrical panel to ensure the equipotential connections of all the metal earths and the structural parts of the unit. The cables must be integrally fixed to the unit's structure using the special cable clamp on the electrical panel.

IMPORTANT

The power cables must have a section adequate for the power absorbed by the unit and be sized in conformity with the current regulations. For sizing of the power supply line, always refer to the unit's total FLI and FLA values, taking into account any accessories fitted.

Protection upstream

An automatic switch suitable for ensuring protection against overcurrents and indirect contacts must be installed upstream. Coordination between the line and switch must be carried out in compliance with the current regulations on electrical safety, regarding the type of installation and the installation ambient conditions.

Connections to be made by the user

The wiring board inside the electrical panel contains dedicated terminals for the following connections.

General alarm

Live output (230V - max 2A) to be used for signalling the presence of an active alarm.

Output active : alarms present

Output not active : alarms absent

Remote standby

A remote device for turning the unit On/Off (selector, programmer clock, centralised supervision device, etc.) with a voltage-free contact suitable for switching loads of very low power can be connected.

This function must be enabled by means of parameter (see the section "Adjustment and control") and has priority over settings made from keyboard.

Remote cooling-heating

It is possible to switch between cooling mode and heating mode from remote by connecting a device equipped with a voltage-free contact suitable for switching loads of very low power.

This function must be enabled by means of parameter (see the section "Adjustment and control") and has priority over settings made from keyboard.

Remote control

It is possible to connect a remote control that has all the control and display functions available on the unit's interface and therefore enable complete remote control.

Pump control

The unit's controller can directly activate the circulating pump by means of a voltage-free contact (max. absorption 4A).

ferroli

Cod. 3QE23650



Ferroli spa - 37047 San Bonifacio (Verona) Italy - Via Ritonda 78/A
tel. +39.045.6139411 - fax +39.045.6100933 - www.ferroli.it